

Indexable Thread Mill System

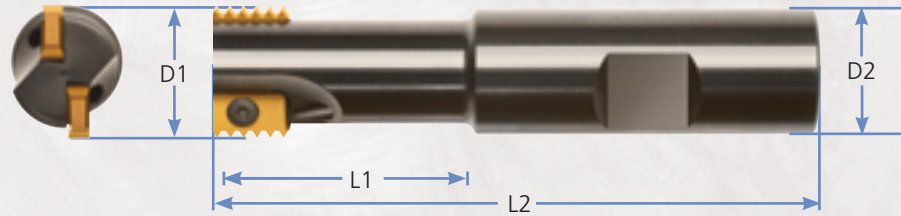

Two Flute Holders

Tool Description	SKU	D2	D1	L2	L1	Flutes	Screw	Insert
TMX 0075 - 79 - 2 - 14	2072103	0.75	0.790	3.75	1.630	2	T7 x M 2.5	14
TMX 0100 - 118 - 2 - 21	2072106	1.00	1.180	4.25	2.000	2	T20 x M 4	21
TMX 0125 - 158 - 2 - 30	2072109	1.25	1.580	5.12	2.850	2	T20 x M 5	30
TMX 0150 - 197 - 2 - 40	2072113	1.50	1.970	6.00	3.250	2	T20 x M 5	40

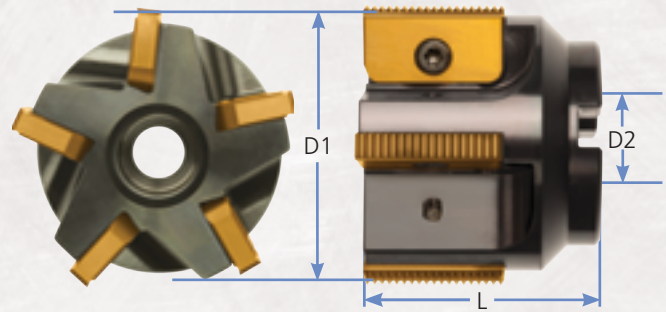

Four Flute Shell Mill Holders

Tool Description	SKU	D2	D1	L	Flutes	Screw	Insert
TMX 0075 - 248 - 4 - 30	4072110	0.75	2.480	1.968	4	T20 x M 5	30
TMX 0100 - 315 - 4 - 30	4072111	1.00	3.150	2.165	4	T20 x M 5	30
TMX 0100 - 315 - 4 - 40	4072114	1.00	3.150	5.12	4	T20 x M 5	40

Screw

Insert Screw	SKU	L	D	P
T7 x M 2.5	SC73102	0.250	2.50 mm	0.45 mm
T20 x M 4	SC73103	0.400	4.00 mm	0.70 mm
T20 x M 5	SC73104	0.480	5.00 mm	0.80 mm

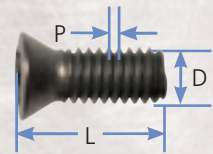

Wrench

Wrench	SKU	Screw size	Insert Size
T7	W73100	T7 x M 2.5	14mm
T20	W73101	T20 x M 4 & T20 x M 5	21, 30 & 40 mm

Indexable Thread Mill System

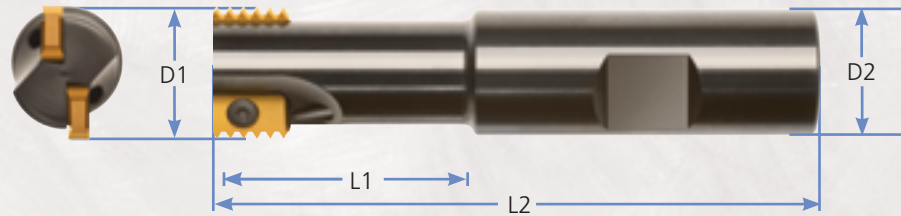

Two Flute Holders

Tool Description	SKU	D2	D1	L2	L1	Flutes	Screw	Insert
TMX - 20 - 20 - 14	2092020	20	20	93	40	2	T7 x M 2,5	14
TMX - 25 - 30 - 21	2092530	25	30	108	50	2	T20 x M 4	21
TMX - 32 - 40 - 30	2093240	32	40	130	70	2	T20 x M 5	30
TMX - 40 - 50 - 40	2094050	40	50	153	82	2	T20 x M 5	40

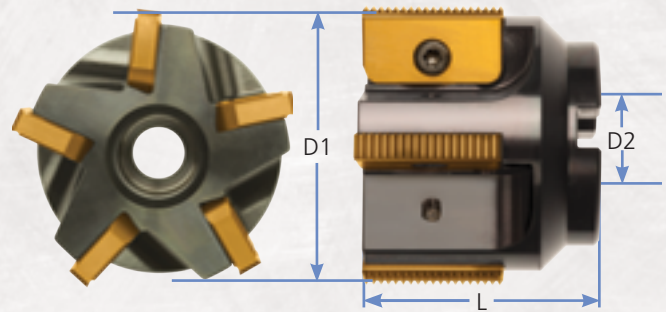

Four and Five Flute Shell Mill Holders

Tool Description	SKU	D2	D1	L	Flutes	Screw	Insert
TMX - 22 - 63 - 30	4096322	22	63	50	4	T20 x M 5	30
TMX - 27 - 80 - 30	5098027	27	80	55	5	T20 x M 5	30
TMX - 27 - 80 - 40	5098028	27	80	65	5	T20 x M 5	40
TMX - 32 - 100 - 30	5090032	32	100	60	5	T20 x M 5	30
TMX - 32 - 100 - 40	5090033	32	100	70	5	T20 x M 5	40

Screw

Insert Screw	SKU	L	D	P
T7 x M 2,5	SC73102	6,35 mm	2,50 mm	0,45 mm
T20 x M 4	SC73103	10,16 mm	4,00 mm	0,70 mm
T20 x M 5	SC73104	12,19 mm	5,00 mm	0,80 mm

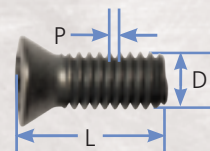

Wrench

Wrench	SKU	Screw size	Insert Size
T7	W73100	T7 x M 2,5	14mm
T20	W73101	T20 x M 4 & T20 x M 5	21, 30 & 40 mm